

City of London Retrofit Sprinkler Schemes

Feasibility Study into Retrofit Sprinkler Systems at Eight Tower Blocks

Barbican – 3 Tower Blocks



Avondale – 3 Tower Blocks



City of London Retrofit Sprinkler Schemes

Middlesex Estate – 1 Tower Block



Golden Lane Estate- 1 Tower Block



City of London Retrofit Sprinkler Schemes

INDEX

	Page
Executive Summary	1
CoL Fire Officer	2
Options/Proposed Systems	3
Barbican Estate tower blocks	4
Avondale Estate tower blocks	8
Middlesex Estate tower block	11
Golden Lane Estate tower block	14
All schemes General Considerations	17
Cost spread sheet	22
Sketch Drawings	23

City of London Retrofit Sprinkler Schemes

Executive Summary

City of London (CoL) have commissioned Butler & Young Associates (BYA) to prepare a feasibility study into the potential retro-fitting of water suppression systems (sprinklers) into the CoL's 8 high rise blocks, the report is to contain at least the following for each block.

- Practicalities of installing such a system (can it be done?);
- Benefits of installing such a system (compared to other potential fire safety measures such as alarms etc);
- Risks associated with installation;
- Potential costs;
- Structural problems (water storage/supply and the like);
- Limitations and restrictions etc.

CoL objective is to reduce risk of the consequences of a fire.

The blocks all comprise multi person accommodation.

The study has reviewed the following aspects: water supplies, pipework distribution, sprinkler head positions, fire escape routes and smoke/fire detection systems, it has not looked into fire compartmentation.

We have consulted with London Fire Brigade (LFB) in the preparation of this report for the Barbican Estate towers. At the time of issue we await input from the CoL Fire Officer.

This report includes adequate information to take these proposals to the next stage i.e. it provides sufficient design intent to reduce price risk of allowing an approved contractor to undertake their design/interpretations independently without guidance.

Costs within this report include for concealing both the sprinkler heads and pipework as much as possible.

Costs within this report also cover the thermal insulation of the pipework, where necessary, to minimise the risk of freezing.

The costs do not include for the required asbestos R&D surveys, removal of asbestos or any controlled works within areas of asbestos.

The costs do not include for all or any part of a smoke/fire alarm system.

The costs do not include for any fire compartmentation other than making good following the installation of the new sprinkler system.

City of London

Retrofit Sprinkler Schemes

CoL Fire Officer

We have asked for confirmation of certain elements from the CoL Fire Officer and replies that will impact on this report.

Questions asked:-

All blocks

- Sprinkler systems for all blocks to comply with BS 9251- 2014, please confirm.

Barbican - 3 Tower blocks

- Can the supply to the new sprinkler pumps be taken from the Wet riser tank marrying pipes?
- Please confirm if just one operational alarm is required, i.e. adjacent to the sprinkler pump or would an alarm be required in each apartment? There is a fire alarm to each so therefore may not require the sprinkler alarm to each.
- External escape routes which pass other apartment windows: As each room will be protected we have assumed that the windows will not require drenching. Please could you confirm?
- Is protection required to any of the escape routes from the lift lobbies. We have allowed for lift lobbies to be protected

Avondale - 3 Tower blocks

- There are no fire alarms to this block, will separate fire alarm indication be required from each flat connected to 24/7 man security?
- We did not see a standby generator, please could you clarify whether Firemans lift has a dual supply and whether emergency lights are battery packed?

Middlesex Estate Petticoat Tower

- There are no fire alarms to this block, will separate fire alarm indication be required from each flat connected to 24/7 man security?
- We did not see a standby generator, please could you clarify whether Firemans lift has a dual supply and whether emergency lights are battery packed?
- Middlesex Street has only one means of escape stairway.

Golden Lane Estate – Great Arthur House

- There are no fire alarms to this block, will separate fire alarm indication be required from each flat connected to 24/7 man security?
- We did not see a standby generator, please could you clarify whether Firemans lift has a dual supply and whether emergency lights are battery packed?

City of London Retrofit Sprinkler Schemes

Options/Proposed Systems

There are 2 options i.e. a fixed automatic sprinkler system or a water mist system

A fixed domestic automatic sprinkler system will comply with BS 9251- 2014, which will also include for the communal areas that impose a risk to the residents for means of escape.

A water mist system will require a pump set in each dwelling which will be a high maintenance issue and would not extend into the communal areas. We therefore consider that this type of system would not to be suitable for these blocks.

The BS does not require each flat to be alarmed to notify of sprinkler operation, only for the main pump. We have not allowed for the alarm to be connected to any 24/7 emergency care system but this can be easily undertaken to provide an alarm in the event of sprinkler operation to enable LFB to be called.

Separate flat alarms maybe a client desirable but have not been included.

There is inadequate pressure within the water main supplies to provide both the flow/pressure requirements to the highest sprinkler heads and therefore separate water storage or around 5,000 litres maximum will be required with a single pump unit sized to suit the required flow and pressures in compliance with BS 9251-2014. Alternatively, subject to confirmation with CoL Fire Officer it may be possible to use the wet riser tanks for the water source of the new sprinkler system within the Barbican Estate towers.

Due to the pressure provided at the lower levels from the booster pump and to ensure that there is adequate pressure to serve the highest heads it may be necessary to provide inline pressure reducing valves on the branch supplies. This will be confirmed during the design process and we have made an allowance for these in the cost.

We are aware that the residential sprinkler regulations allow for connections to be taken from the domestic boosted system but in our opinion this is not a preferred method as it creates excessive dead legs which will dramatically increase the risk of legionella bacteria growth with potential colonisation of the domestic water system.

City of London Retrofit Sprinkler Schemes

The following are our proposals for each of the blocks/sites

Barbican

This site consists of 3 tower blocks

There is communal basement car parking throughout. The car parks already have their own fully operational sprinkler system. These systems are currently being modified from a wet to an alternate system, and do not form part of this study.

There is a fire alarm system with a detector in each flat and alarm panel at reception. There are no detectors in the communal lift lobby areas.

There is a communal services tunnel that interconnects throughout the site. As this is a possible avenue for the fire to spread, sprinklers will be allowed from each of the residential blocks systems to the lobby accessing this tunnel to lower this risk.

We did not notice any Gerda boxes to provide the necessary information for the fire brigade but understand they make regular visits to the site and are familiar with all firefighting systems installed.

Lauderdale Tower

- Construction 1970
- 41 residential floors (117 flats) with 2 basement plant areas
- Basement – Wet riser plant area, Domestic water plant area, Garchey waste collection disposals area and residents' stores.
- Standby generator for emergency lighting and Firemans lift
- The block has been provided with a wet riser system having its own water storage tanks, electric & diesel pumps, wet riser outlet valve at each level (mainly in the lift lobbies) and fire brigade infill valve.
- The block has been provided with one Firemans lift for use by LFB during an emergency.
- There is asbestos throughout.
- Reception double height.
- Floors 1 to 37 – 3 flats on each
- Floors 38 & 39 – 2 flats on each
- Floors 40 & 41 - Penthouses

City of London

Retrofit Sprinkler Schemes

Shakespeare Tower

- Construction 1970
- No service subway to this block
- 41 residential floors (116 flats) with 2 basement plant areas
- Basement – Wet riser plant area, Domestic water plant area, Garchey waste collection disposals area and residents' stores
- Standby generator for emergency lighting and Firemans lift
- The block has been provided with a wet riser system having its own water storage tanks, electric & diesel pumps, wet riser outlet valve at each level (mainly in the lift lobbies) and fire brigade infill valve
- The block has been provided with one Firemans lift for use by LFB during an emergency
- There is asbestos throughout
- Reception double height
- Floor 1 - 2 flats
- Floors 2 to 37 – 3 flats on each
- Floors 38 & 39 – 2 flats on each
- Floors 40 & 41 – Penthouses

Cromwell Tower

- Construction 1970
- 39 residential floors (111 flats) with 2 basement plant areas
- Basement – Wet riser plant area, Domestic water plant area, Garchey waste collection disposals area and residents' stores
- Standby generator for emergency lighting and Firemans lift
- The block has been provided with a wet riser system having its own water storage tanks, electric & diesel pumps, wet riser outlet valve at each level (mainly in the lift lobbies) and fire brigade infill valve
- The block has been provided with one Firemans lift for use by LFB during an emergency
- There is asbestos throughout
- Reception double height
- Floors 1 to 35 – 3 flats on each
- Floors 36 & 37 – 2 flats on each
- Floors 38 & 39 – Penthouses

City of London Retrofit Sprinkler Schemes

Typical proposals for each Barbican block

We propose three risers, one in each plumbing riser which are independently accessed on every floor and will provide access/entry into each flats without crossing the communal lift lobby areas.

The lift lobby communal areas can be protected by side wall sprinklers from each riser which will require drilling through and fitting to the lift lobby walls.

The means of escape area can also be protected by the same method off each riser.

All basement areas that contain fire protection plant, equipment or pipework will be protected, residential stores area will be protected together with lobby entrances to communal service tunnels.

We were able to access two flats, one in Shakespeare tower which is close to being refitted out by the leaseholder, plaster board ceilings have been added throughout and the other being flat 152 in Cromwell tower which has the original plastered/concrete ceilings.

Intent would be to run a new sprinkler main along the dwelling hallway with recessed side wall sprinklers into each / every room and recessed pendant heads along the hallway. This would require a slightly dropped plasterboard ceiling throughout the length of the hallway and all necessary modifications to ceiling lights, local tenant fitted alarms, etc.

Questions

- Practicalities of installing such a system (can it be done?)
The answer is yes as proposals verifies
- Benefits of installing such a system (compared to other potential fire safety measures such as alarms etc)
The fire is contained until LFB arrive
Towers have fire alarm system therefore this comparison is irrelevant
Sprinklers can be provided to the means of escape stairway which currently are unprotected
There is no alternate escape stairway route from the lift lobby areas and sprinklers would assist in protecting the current route
May reduce the requirement for preventing internal fire spread via the construction
- Risks associated with installation
Minimum risk other than normal building construction works which would be covered by method statements on how the works are to be installed.
Asbestos surveys and removals if in the area of the intended works.

City of London Retrofit Sprinkler Schemes

- Potential costs
As attached
- Structural problems (water storage/supply and the like)
There are none
- Limitations and restrictions etc.
Listed building approval

Estimated Cost - Barbican

Exclusive of any Asbestos works, VAT and Fees

Lauderdale Tower	£613,818.00
Shakespeare Tower	£608,764.00
Cromwell Tower	£581,594.00

City of London Retrofit Sprinkler Schemes

Avondale Estate

This site consists of 3 tower blocks, West, Central and East, all of which are typical throughout.

There is no fire alarm system to these blocks, the only facility is if each tenant or leaseholder have fitted their own local detectors/alarm but this does not provide warning to other occupiers or LFB during an emergency.

Gas meters/risers are within cupboards within each flat which appear not to be ventilated or fire compartmented.

Each block has a dry riser with an outlet at every other floor adjacent to the Firemans lift.

There are two lifts which service alternate floors and one of the lift is for use by the fire brigade.

We were unable to locate a standby generator for use of both the lift and lights during emergency and assume that the lift will have a dual electrical supply and emergency lights are of the battery pack type.

There are two central risers accessed from the lift lobby and internal access stairs, one being electrical in the lift lobby the other being the dry riser in the stairway, service risers are within the demise of the flats.

There is an internal access stair and partly covered external means of escape stairs with open side.

Each Tower

- Construction 1960s.
- 19 residential floors (74 flats) no basement areas.
- Ground floor – Dry riser inlet, Domestic water plant area, Electrical intake and Waste collection disposals area.
- Residents' stores are separate and externally located. No protection required.
- Provided with a dry riser system with outlet landing valves at alternate floors.
- Each block has been provided with one Firemans lift for use by LFB during an emergency with exit on the same level as the dry riser landing valves.
- It is believed there is asbestos throughout.
- There are two stairways from each lift lobby area
- Ground floor - 2 flats.
- Floors 1 to 18 – 4 flats on each.
- Mainly consists of studio and one bedroom flats.

City of London Retrofit Sprinkler Schemes

Typical proposals for each Avondale block

It would be difficult to install the new sprinkler riser into the same riser as the dry riser as access into this duct is restricted.

Access for sprinkler pipework into the service riser duct would mean accessing and drilling within the demise of each of the flat, the best location if this was to be considered within the flat demise would be alongside the gas riser but it would be extremely intrusive to install.

We therefore believe the best solution would be to locate the riser in the rear external, partly covered means of escape stair which would require the new main to be thermally insulated and boxed to prevent freezing, protection and concealment. We do not believe this would be a planning concern but it would need to be checked.

The new sprinkler main could branch from the riser to each flat, running at high level in each lift lobby area with insulation to prevent freezing and boxing to protect and conceal.

The lift lobby communal areas can be protected by sidewall or pendant sprinklers heads, (subject to final solution) from each main routing to the flats. The means of escape area can also be protected, if necessary, by a similar method.

All plant areas that will contain fire protection plant, equipment or pipework will be protected along with block entrance areas.

We were able to access one flat one in West Block which had just been decorated.

Intent would be to run a new sprinkler main down the dwelling hallway with recessed side wall sprinklers into each/every room and recessed pendant heads along the hallway, this would require slightly dropped plasterboard ceiling throughout the length of the hallway and all necessary modifications to ceiling lights, local tenant fitted alarms, etc.

Questions

- Practicalities of installing such a system (can it be done?)
The answer is yes as proposals verify
- Benefits of installing such a system (compared to other potential fire safety measures such as alarms etc)
The fire is contained until LFB arrive
Provides LFB by indication the location of the fire
May prevent the need to have a fire alarm system – would need Fire Officer comment
Sprinklers can be provided to the means of escape stairways which currently are unprotected

City of London Retrofit Sprinkler Schemes

May reduce the requirement for preventing internal fire spread via the construction

- Risks associated with installation
Minimum risk other than normal building construction works which would be covered by method statements on how the works are to be installed.
Asbestos surveys and removals if in the area of the intended works.
- Potential costs
As attached
- Structural problems (water storage/supply and the like)
There are none
- Limitations and restrictions etc.
Possibly planning

Estimated cost - Avondale

Exclusive of any Asbestos works, smoke/fire alarm systems VAT and Fees

West Tower	£431,096.00
Central Tower	£431,096.00
East Tower	£431,096.00

City of London

Retrofit Sprinkler Schemes

Middlesex Estate

This site consists of 1 tower block named Petticoat Tower.

There is no fire alarm system to this block, the only facility is if each tenant or leaseholder have fitted their own local detectors/alarm, but this does not provide warning to other occupiers.

There is communal underground car parking which is protected by a dedicated sprinkler system and has not been considered within this report.

The block has an exposed dry riser with outlets at every other floor that coincide with the Firemans lift.

There are two lifts which serve alternate floors, one is labelled as a fire-fighting lift.

We were unable to locate a standby generator for use of both the fire lift and lights during emergency, we assume that the lift will have a dual electrical supply and emergency lights will be of the battery pack type.

There is an electrical riser within the lift stair lobby. We assume that all other risers are within the flat demise.

There is only one escape stairs off the lift lobby core which exits at podium level (level 2).

The internal access stair is also the means of escape stairs which has an open side, there is no secondary means of escape.

The refuse chute runs vertically through the whole block within the access/escape stairs.

The whole block with the main walls are of concrete construction with beams.

Petticoat Tower

- Construction 1970s
- 24 floors
- Level 2 (podium) to level 23 each has 4 flats, (92 Flats)
- Level 1 – flats storage units
- Ground floor – flat storage units, plant & refuse areas with communal ground
- Ground & basement communal parking separated from the tower
- Lifts access alternate floors
- Ground floor – Dry riser inlet, Domestic water plant area, Electrical intake and waste collection disposals area

City of London Retrofit Sprinkler Schemes

- Residents' stores are on levels ground and 1
- Provided with a dry riser system with outlet landing valves at alternative floors.
- Each block has been provided with one Firemans lift for use by LFB during an emergency, with exit on the same level as the dry riser landing valves
- It is believed there is asbestos
- Flats are an even mixture off one and two bedroom having two off each at each level (flats A& D being the two bedroom, B&C being the one bedroom)
- Concrete beams within flats that will require drilling
- Pipework to be extended from dwelling hallway to reach furthest corners within each flats.
- Only one stairway
- No secondary means of escape from each flat

Proposals for Petticoat Tower

The best location for a new sprinkler riser would be in the corner adjacent to refuse chute, as this could be installed without disturbing the tenants.

From the new risers, sprinkler pipework could be routed at high level across the access stairway lobby and into the lift lobby, drilled holes will be required. The sprinkler main could then follow the contours of the lift lobby at high level in the corners between walls/ceilings to enter each flat at high level in the dwelling hallways. The whole pipe would be boxed and the section in the stairway lobby and riser be thermally insulated to prevent freezing.

Drilling would be required through all concrete walls along the pipework route and through the floors for the riser.

Sprinkler heads would be provided within the access stairway lobby, refuse chute and the lift lobby to provide protection to these areas.

All plant areas that will contain fire protection plant, equipment or pipework will be protected along with block entrance areas.

We were able to access a one bedroom flat which had just been decorated, which revealed a down stand concrete beam that the new sprinkler pipe will have to penetrate.

Intent would be to run a new sprinkler main down the dwelling hallway with recessed side wall sprinklers into each/every room off the hallway with recessed pendant heads along the hallway, this would require a slightly dropped plasterboard ceiling throughout the length of the hallway and all necessary modifications to ceiling lights, local tenant fitted alarms, etc.

Due to the extremities of the flat in the lounge and kitchen a supply would need to be extended into these rooms located in the ceiling to the wall corner with suitable boxing to permit all areas of the flat to be covered.

City of London Retrofit Sprinkler Schemes

Questions

- Practicalities of installing such a system (can it be done?)
The answer is yes as proposals verify
- Benefits of installing such a system (compared to other potential fire safety measures such as alarms etc)
The fire is contained until LFB arrive
Provides LFB by indication the location of the fire
May prevent the need to have a fire alarm system
There are no secondary means of escape from each flat or an alternate escape route from the lift lobby areas
Provides additional protection to each flat which have no secondary means of escape
Provides protection to the one means of escape stairway
May reduce the requirement for preventing internal fire spread via the construction
- Risks associated with installation
Minimum risk other than normal building construction works which would be covered by method statements on how the works are to be installed.
Asbestos surveys and removals if in the area of the intended works.
- Potential costs
As attached
- Structural problems (water storage/supply and the like)
Downstand beam penetration to be checked
- Limitations and restrictions etc.
There are none

Estimated cost

Exclusive of any Asbestos works, smoke/fire alarm systems VAT and Fees

Petticoat Tower **£537,768.00**

City of London

Retrofit Sprinkler Schemes

Golden Lane Estate

This site consists of 1 tower block named Great Arthur House.

There is no fire alarm system to this block, the only facility is if residents or leaseholders have their own local detectors/alarm but this does not provide warning to other occupiers.

The block has an exposed dry riser with an outlet at every other floor which coincides with the Firemans lift.

The dry riser rises adjacent the vertical refuse chute in one of the stairways.

There is a stairway each end of the block, both of which are partly open.

Each flat has a separate escape route from its demise into either the lift lobby or stairway subject to the location of the flat.

There are two lifts which serve alternate floors, which are located centrally on each floor, one is labelled as a fire-fighting lift.

Between the lift and end stairways there are 4 flats on each side.

We were unable to locate a standby generator for use of both the fire lift and lights during emergency, we assume that the lift will have a dual electrical supply and emergency lights are of the battery pack type.

We believe there are electrical risers outside the flats but were unable to confirm this as panels need to be unfixd to access; most other risers are within the flat demise.

The whole block with the main walls are of concrete construction with beams.

Great Arthur House

- Construction 1958 -1960
- 16 floors
- Level 1 to 15 have 8 flats each, (120 Flats)
- Ground floor – Reception, external boiler room, dry riser inlet
- Basement – Flat storage units, other plant areas & refuse collection area
- Two lifts that access alternate floors
- Provided with a dry riser system with outlet landing valves at alternative floors.

City of London

Retrofit Sprinkler Schemes

- Provided with one Firemans lift for use by LFB during an emergency, with exit on the same level as the dry riser landing valves
- There is asbestos, wall between bathroom and kitchen in each flat is asbestos
- Flats are one bedroom having 8 at each level
- Flats and lift lobbies have secondary means of escape

Typical proposals for Great Arthur House

The best location for a new sprinkler riser would be in the corner adjacent to refuse chute dry riser, as this could be installed without disturbing the tenants.

From the new risers, sprinkler pipework could be routed at high level across the full extent of each floor lobby, drilled holes will be required. The sprinkler main could then follow the contours of the lobby at high level in the corners between walls/ceilings to enter each flat at high level in the dwelling hallways. The whole pipe would be boxed in and the section in the stairway lobby and riser be thermally insulated to prevent freezing.

Drilling would be required through all concrete walls along the pipework route and through the floors for the riser.

Sprinkler heads would be provided within the stairways and lobbies to provide protection to these areas.

All plant areas that will contain fire protection plant, equipment or pipework will be protected along with block entrance areas.

We were able to access a one bedroom flat (101) which had just been decorated. There is a wall containing asbestos between the kitchen/bathroom. The extremities of two rooms will not be covered by sidewall sprinklers in the hallway due to distance.

Intent would be to run a new sprinkler main down the dwelling hallway with recessed side wall sprinklers into each/every room off the hallway with recessed pendant heads along the hallway, this would require slightly dropped plasterboard ceiling throughout the length of the hallway and all necessary modifications to ceiling lights, local tenant fitted alarms, etc.

Due to the extremities of the flat in the lounge and bedroom a supply would need to be extended into these rooms located in the ceiling to the wall corner with suitable boxing to permit all areas of the flat to be covered.

City of London Retrofit Sprinkler Schemes

Questions

- Practicalities of installing such a system (can it be done?)
The answer is yes as proposals verify
- Benefits of installing such a system (compared to other potential fire safety measures such as alarms etc)
The fire is contained until LFB arrive
Provides LFB by indication the location of the fire
May prevent the need to have a fire alarm system
Provides additional protection to each flat
Provides protection to the means of escape stairways
May reduce the requirement for preventing internal fire spread via the construction
- Risks associated with installation
Minimum risk other than normal building construction works which would be covered by method statements on how the works are to be installed.
Asbestos surveys and removals if in the area of the intended works.
- Potential costs
As attached
- Structural problems (water storage/supply and the like)
There are none
- Limitations and restrictions etc.
There are none

Estimated cost

Exclusive of any Asbestos works, smoke/fire alarm systems VAT and Fees

Great Arthur House £676,880.00

City of London Retrofit Sprinkler Schemes

ALL SCHEMES GENERAL CONSIDERATIONS

City of London Retrofit Sprinkler Schemes

Typical Sprinkler heads within the flats

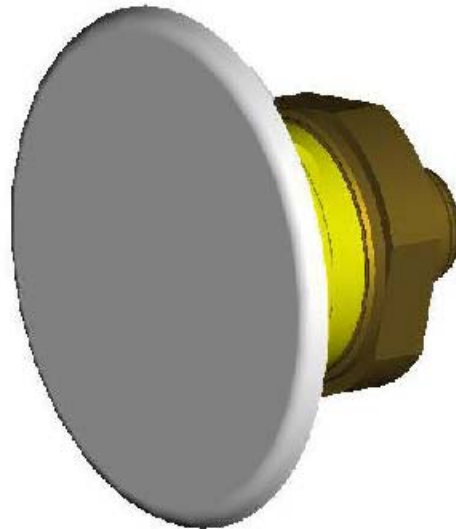

SIDE WALL SPRINKLER PLATE



CEILING SPRINKLER PLATE

City of London Retrofit Sprinkler Schemes

Retrofit Sprinkler Scheme – All Schemes

Connection from the water mains will be required to a sprinkler break tank located in the plant room areas (Barbican towers hopefully will be taken from the wet riser tanks) – subject to Fire Officer approval.

These will be a sprinkler pump unit feeding a new riser in each Tower serving all Tower levels, flats and stores.

Sprinkler pipework will be distributed at each floor level to the communal lobbies and extending into the apartments. (See drawings).

The sprinkler heads will be hidden and covered by a white 80mm flat plate.
In a fire scenario the plate will drop at around 50Deg C revealing the sprinkler head behind.

Statistically the risk of accidental discharge is approx. 16,000,000:1.

Disruption

There will be some noisy works whilst the risers are being installed as this will route through floors. The infill material between floors is currently unknown assumed as concrete.

There will also be noise from drilling and fixing of pipework.

There will be disruption in the lobby areas that the installer will have to control and monitor to ensure safety of the public.

We have been told by CoL that towers do contain asbestos therefore R&D surveys will be required and any asbestos located in the areas of the new sprinklers will need to be removed, which will be additional to the cost identified in this report.

City of London Retrofit Sprinkler Schemes

Detailed Design Consideration

Retro fit sprinkler system considerations for all Tower blocks

Design based on BS9251:2014.

Flow & Pressures

Boosting required due to the lack of available pressure from the watermain to reach the upper most levels.

Flow - 4 heads operating simultaneously @ 42 l/m each = 168 l/min.

Pressure – minimum of 0.5 bar (5m) at any sprinkler.

A dedicated power supply would be required to the pump set.

All sprinkler heads are subject to malicious damage and there is little that can be done to reduce this risk. Accidental discharge risk is negligible. The heads propose will have flat 65mm diameter white concealment covers that are soldered in position. During operation the solder covers fall off at a lower temperature exposing the sprinkler head bulb to the heat source.

We propose for the pipework to be plastic based and concealed in new ceilings and corner bulkheads. This material permits the installation to be kept as tight as possible to the existing fabric.

Our intent is to provide new false ceilings in each dwelling as the typical section included with the drawings in this report.

The precise number and location of sprinkler heads will be subject to the designer's engineer's calculations and spray patterns of heads selected.

City of London Retrofit Sprinkler Schemes

Tender Process

Following our design should the works proceed, it is proposed that we invite tenders from 5 No. residential sprinkler specialist installers.
(depends on CoL tendering standard requirements)

NB The final design including the number of sprinklers and their positions will be determined by the contractor. (BS requirement).

City of London Retrofit Sprinkler Schemes

CoL sprinklers cost spread sheet

Flat cost based on the highest tender for Parkside
Chelmsford 2595

<u>Tower block</u>	<u>No of flats</u>	<u>Cost each</u>	<u>Total</u>	<u>Fire Alarm</u>	<u>Standby Generator</u>	<u>PRV to each branch</u>	<u>Additional boxing</u>	<u>Sprinkler Alarm</u>	<u>TOTAL</u>
		£5,054.00				above level 16	Thermal Insulation	each flat	
						£300 each	£100 /M	£400	
Barbican									
Lauderdale Tower	117	£5,054.00	£591,318.00	Yes flats	Yes	£22,500.00	£0.00	£0.00	£613,818.00
Skakespeare Tower	116	£5,054.00	£586,264.00	Yes flats	Yes	£22,500.00	£0.00	£0.00	£608,764.00
Cromwell Tower	111	£5,054.00	£560,994.00	Yes flats	Yes	£20,700.00	£0.00	£0.00	£581,694.00
Avondale Estate									
West Tower	74	£5,054.00	£373,996.00	No	No	£900.00	£26,600.00	£29,600.00	£431,096.00
Central Tower	74	£5,054.00	£373,996.00	No	No	£900.00	£26,600.00	£29,600.00	£431,096.00
East Tower	74	£5,054.00	£373,996.00	No	No	£900.00	£26,600.00	£29,600.00	£431,096.00
Middlesex Estate									
Petticoat Tower	92	£5,054.00	£464,968.00	No	No	£2,400.00	£33,600.00	£36,800.00	£537,768.00
Golden Lane Estate									
Great Arthur House	120	£5,054.00	£606,480.00	No	No	£0.00	£22,400.00	£48,000.00	£676,880.00

City of London Retrofit Sprinkler Schemes

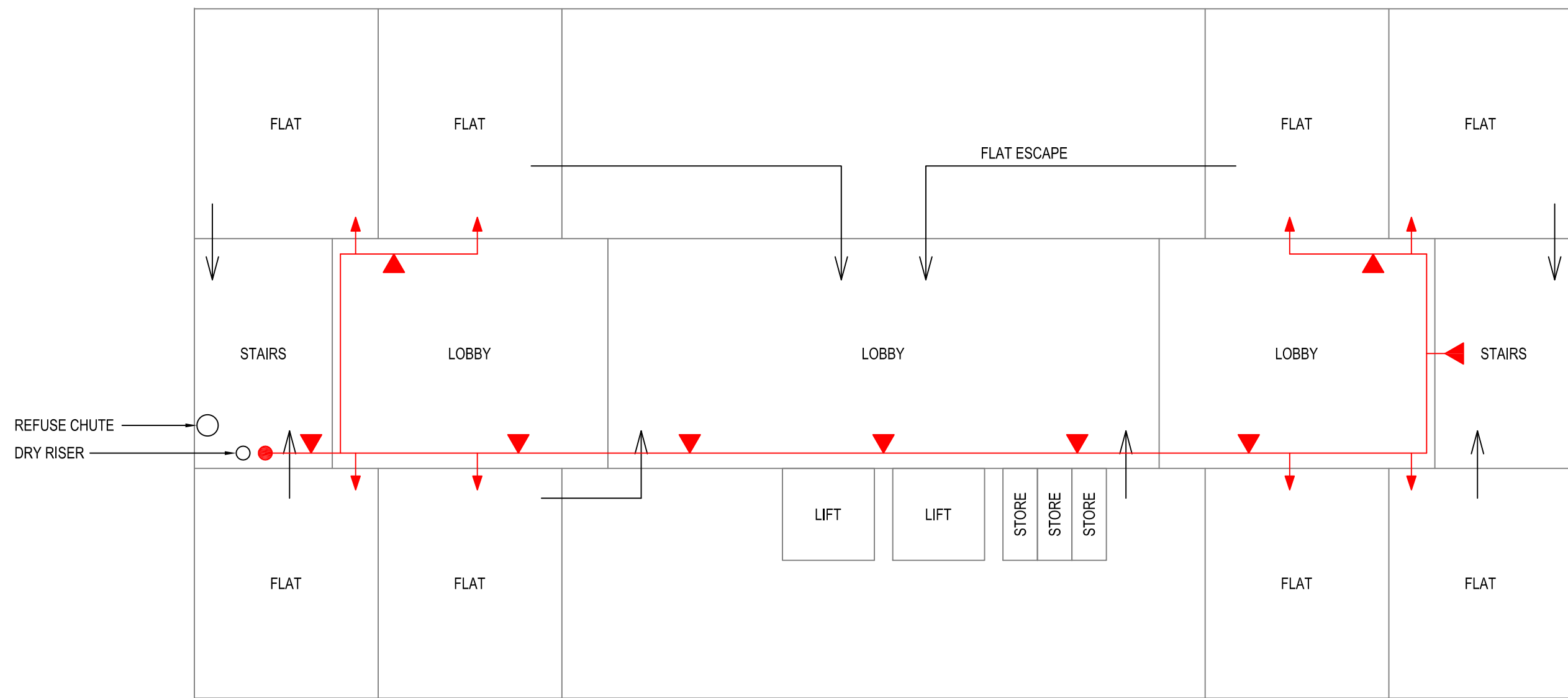

SKETCH DRAWINGS

- LEGEND**
- ▼ TYPICAL SIDE WALL HEAD
 - ↑ TYPICAL SPINKLER MAIN ENTRY
 - TYPICAL SPINKLER RISER
 - ESCAPE



THIS SKETCH DOES NOT REPRESENT A
TRUE ACCURATE LAYOUT.
ITS FOR INFORMATION ONLY

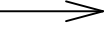

GOLDEN LANE ESTATE
GREAT ARTHUR HOUSE
TYPICAL FLOOR PLAN/PROPOSAL
SCALE (N.T.S.)

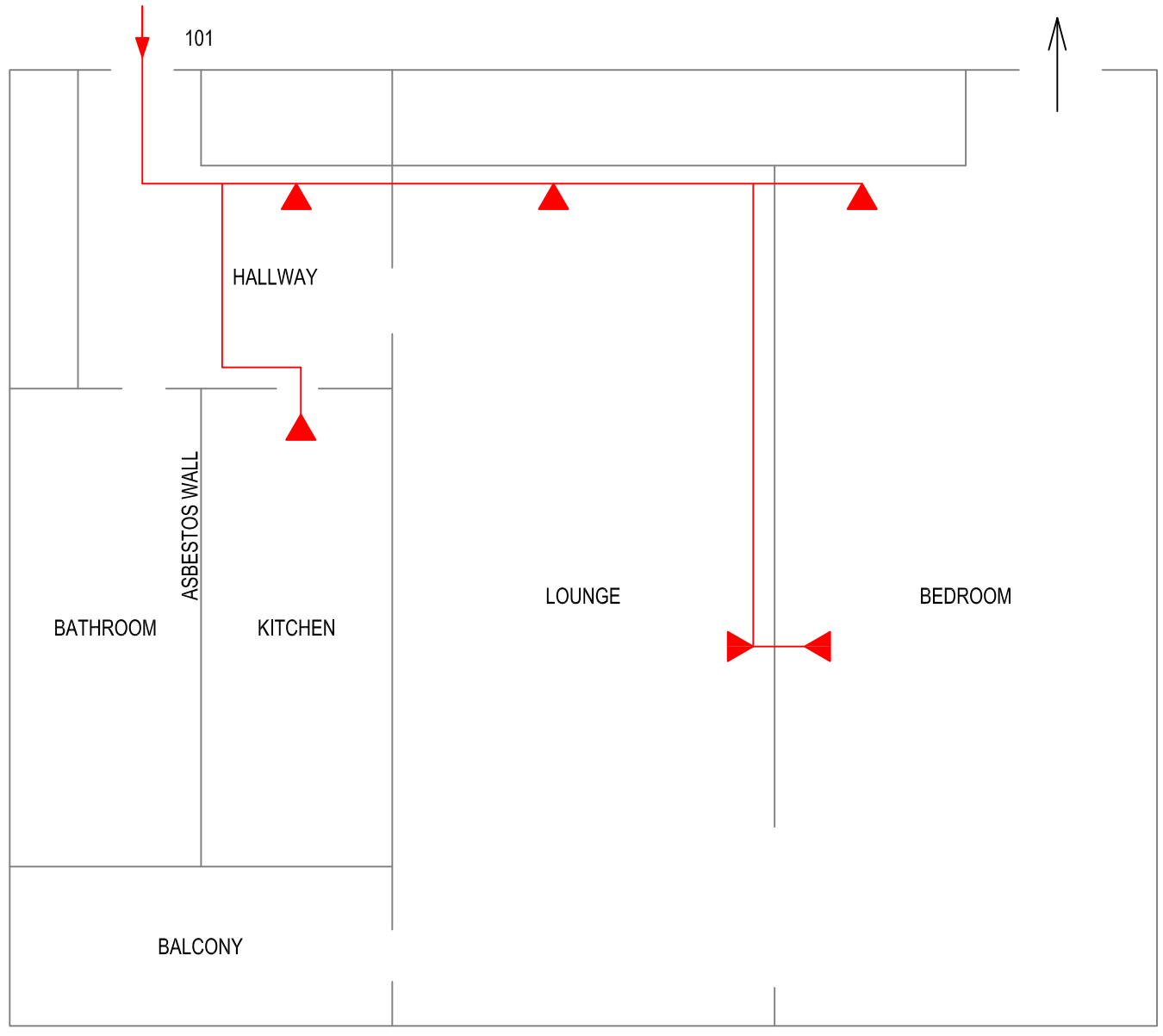
- LEGEND**
-  TYPICAL SIDE WALL HEAD
 -  TYPICAL SPINKLER MAIN ENTRY
 -  TYPICAL SPINKLER RISER
 -  ESCAPE



THIS SKETCH DOES NOT REPRESENT A
TRUE ACCURATE LAYOUT.
ITS FOR INFORMATION ONLY



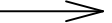

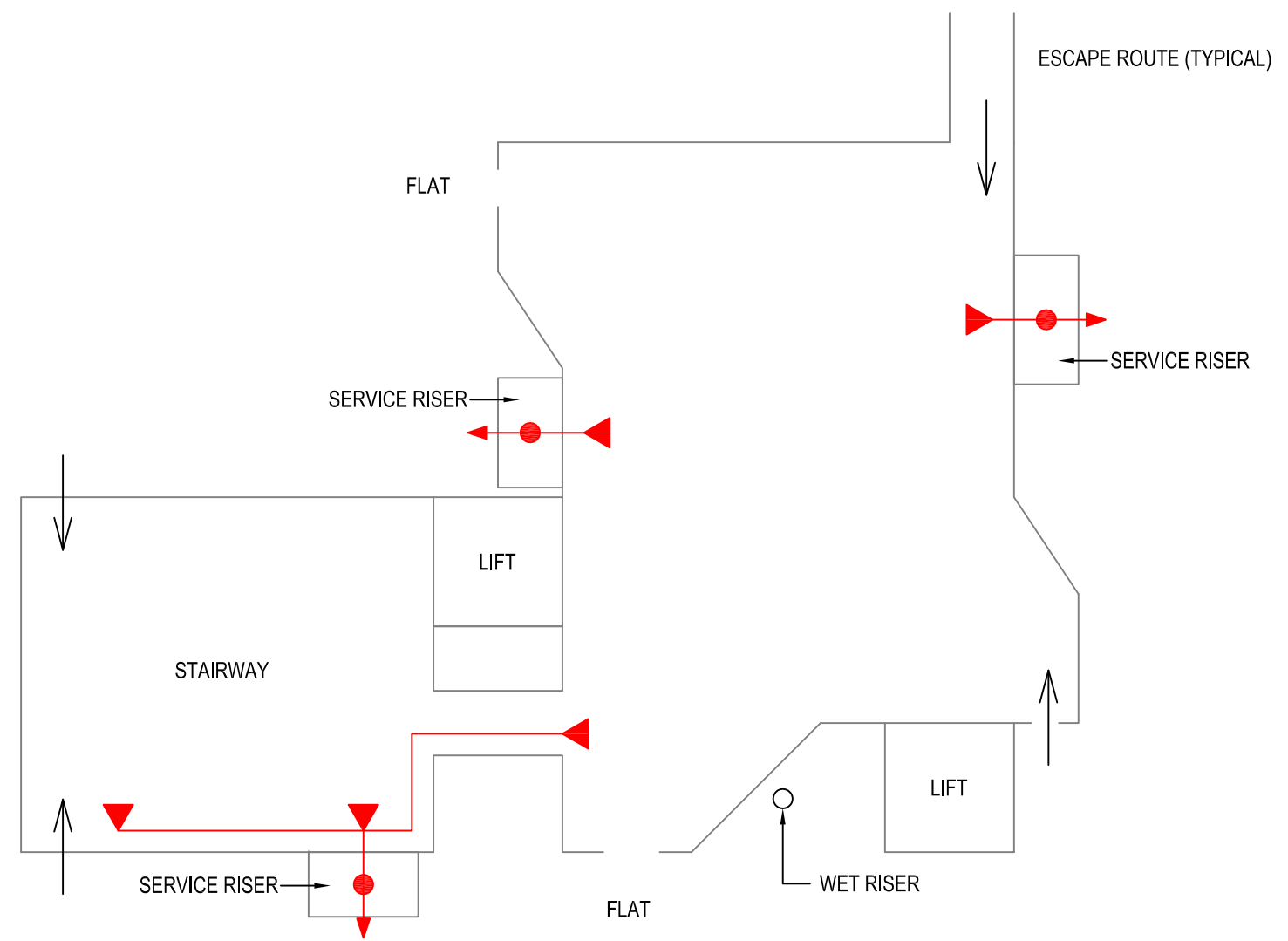
GOLDEN LANE ESTATE
GREAT ARTHUR HOUSE
TYPICAL FLAT LAYOUT/PROPOSAL
SCALE (N.T.S.)

- LEGEND**
-  TYPICAL SIDE WALL HEAD
 -  TYPICAL SPINKLER MAIN ENTRY
 -  TYPICAL SPINKLER RISER
 -  ESCAPE



THIS SKETCH DOES NOT REPRESENT A
TRUE ACCURATE LAYOUT.
ITS FOR INFORMATION ONLY

BARBICAN ESTATE
LAUDERDALE TOWER
TYPICAL FLOOR PLAN/PROPOSAL
SCALE (N.T.S.)

- LEGEND**
-  TYPICAL SIDE WALL HEAD
 -  TYPICAL SPINKLER MAIN ENTRY
 -  TYPICAL SPINKLER RISER
 -  ESCAPE

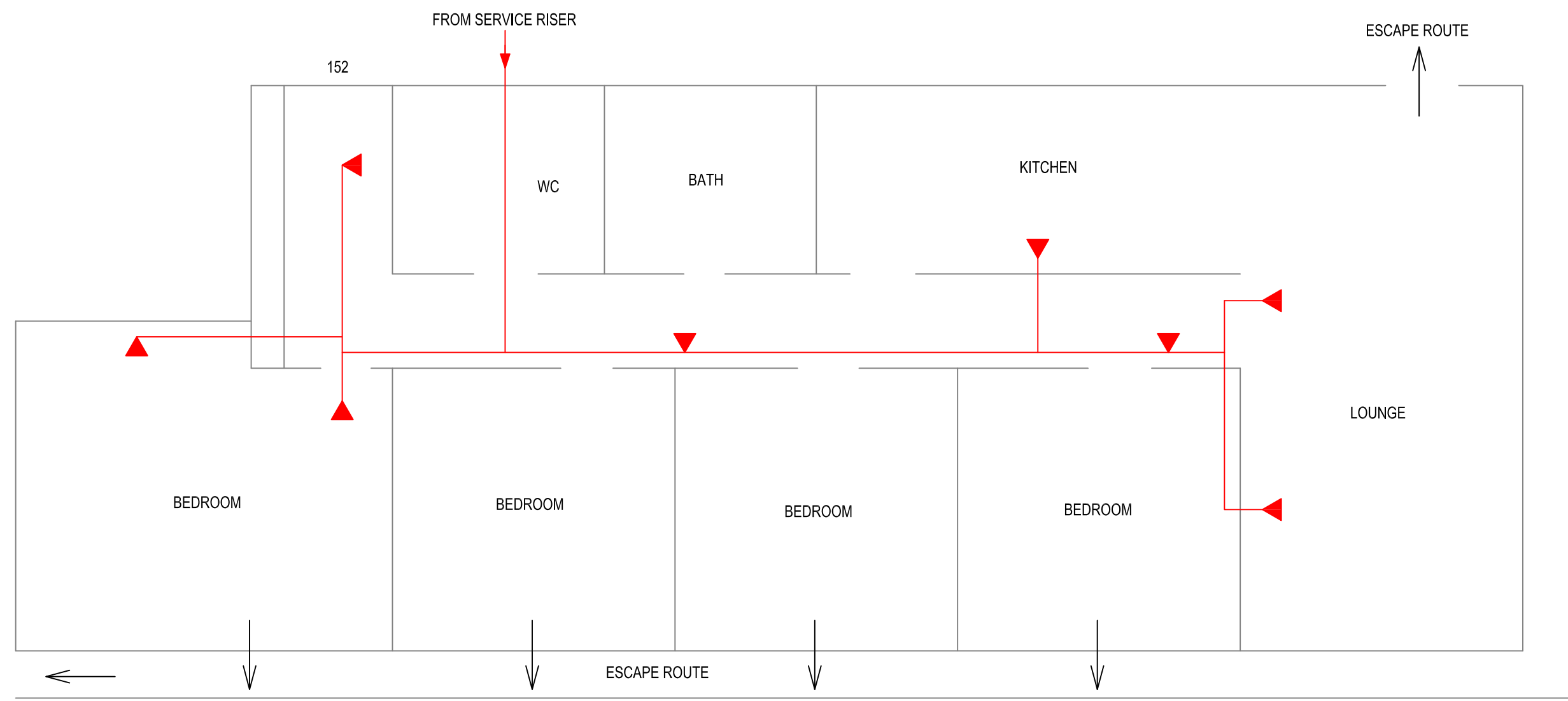

THIS SKETCH DOES NOT REPRESENT A TRUE ACCURATE LAYOUT. ITS FOR INFORMATION ONLY

BARBICAN ESTATE
CROMWELL TOWER
TYPICAL FLAT LAYOUT/PROPOSAL
SCALE (N.T.S.)

- LEGEND**
- ▼ TYPICAL SIDE WALL HEAD
 - ↑ TYPICAL SPINKLER MAIN ENTRY
 - TYPICAL SPINKLER RISER
 - ESCAPE

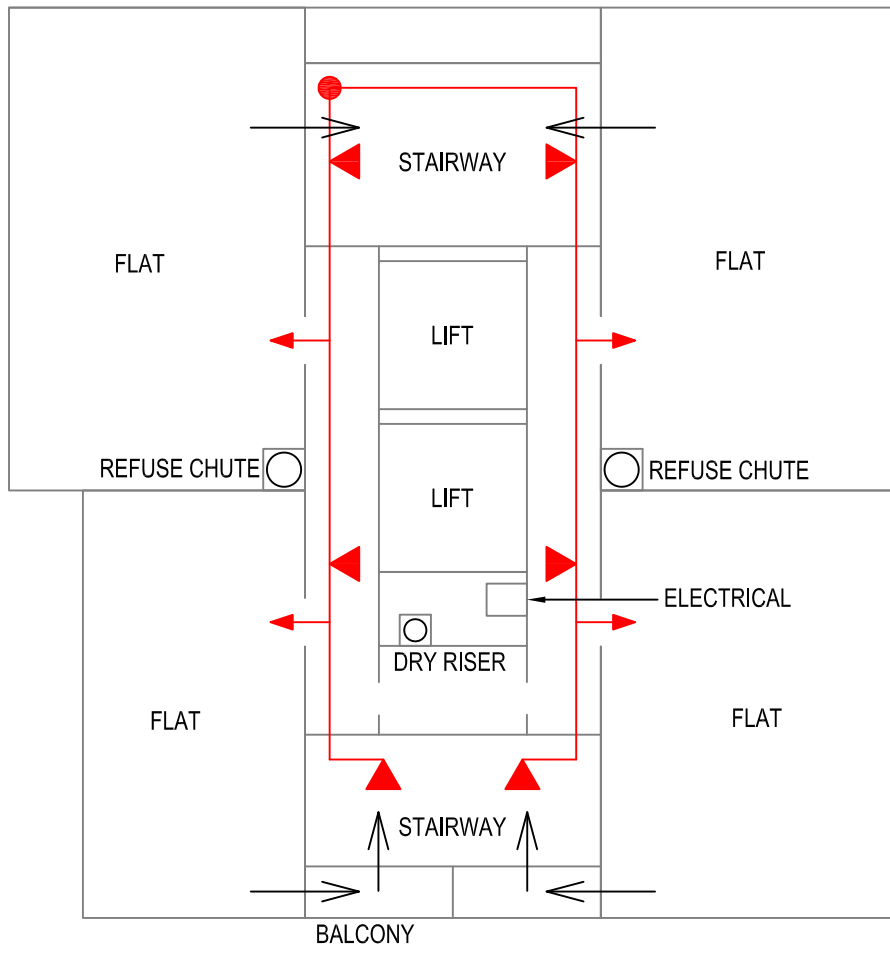

THIS SKETCH DOES NOT REPRESENT A
TRUE ACCURATE LAYOUT.
ITS FOR INFORMATION ONLY

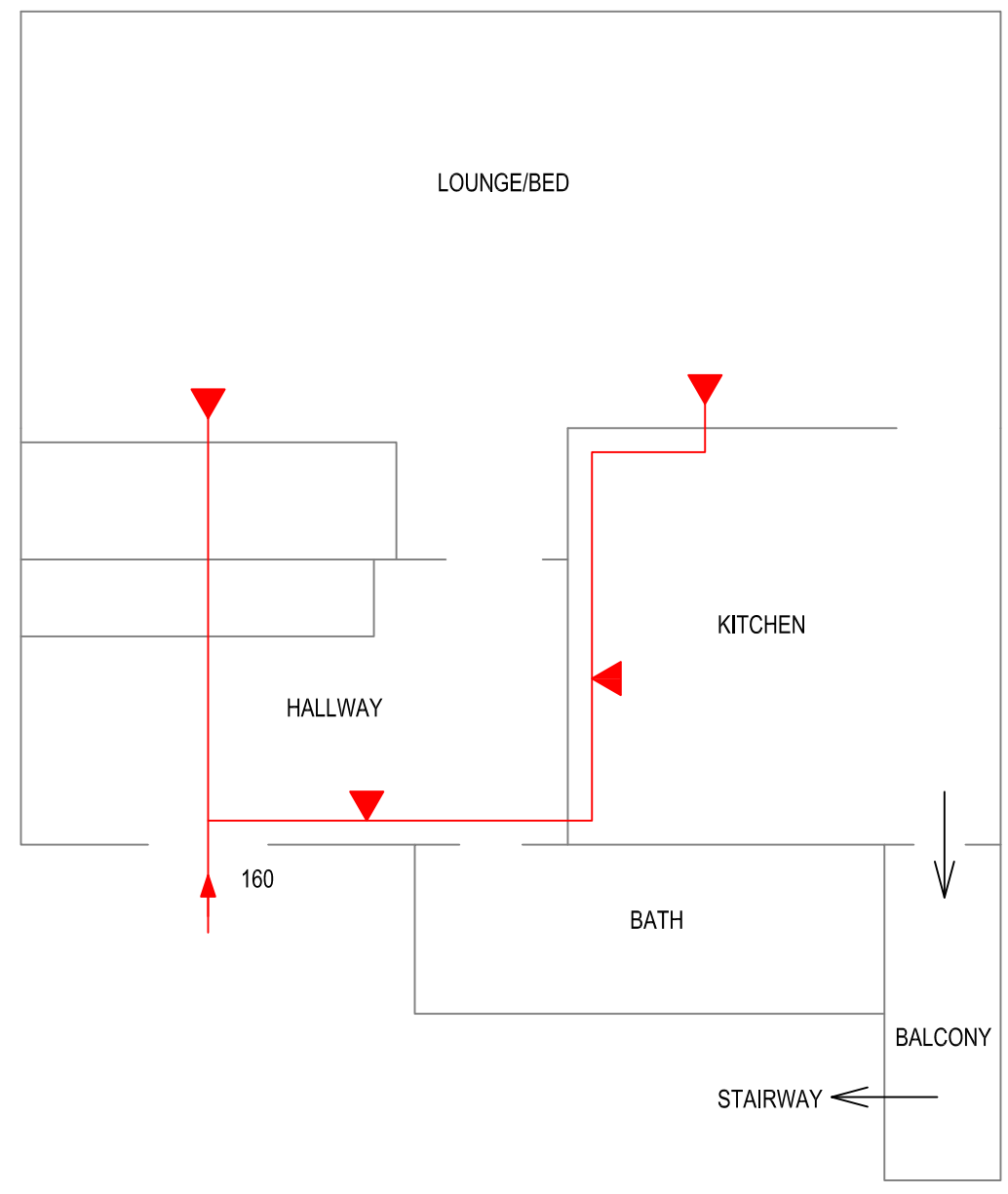

AVONDALE ESTATE
WEST TOWER
TYPICAL FLOOR PLAN/PROPOSAL
SCALE (N.T.S.)

- LEGEND
- ▼ TYPICAL SIDE WALL HEAD
 - ↑ TYPICAL SPINKLER MAIN ENTRY
 - TYPICAL SPINKLER RISER
 - ESCAPE



THIS SKETCH DOES NOT REPRESENT A
TRUE ACCURATE LAYOUT.
ITS FOR INFORMATION ONLY

AVONDALE ESTATE
WEST TOWER
TYPICAL FLAT LAYOUT/PROPOSAL
SCALE (N.T.S.)

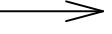
- LEGEND**
-  TYPICAL SIDE WALL HEAD
 -  TYPICAL SPINKLER MAIN ENTRY
 -  TYPICAL SPINKLER RISER
 -  ESCAPE

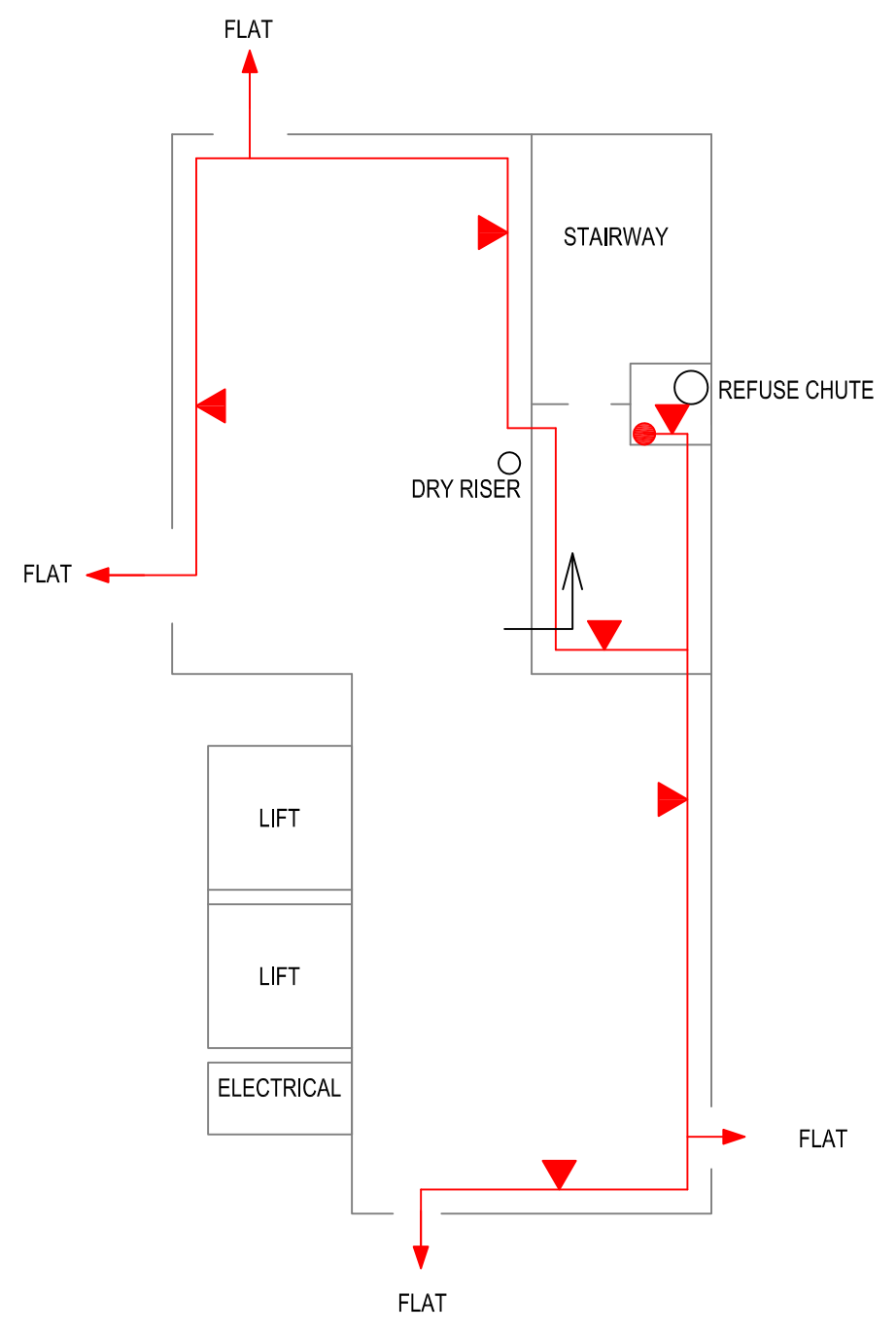

THIS SKETCH DOES NOT REPRESENT A
TRUE ACCURATE LAYOUT.
ITS FOR INFORMATION ONLY

MIDDLESEX ESTATE
PETTICOAT TOWER
TYPICAL FLOOR PLAN/PROPOSAL
SCALE (N.T.S.)

LEGEND

▼ TYPICAL SIDE WALL HEAD

↑ TYPICAL SPINKLER MAIN ENTRY

● TYPICAL SPINKLER RISER

→ ESCAPE

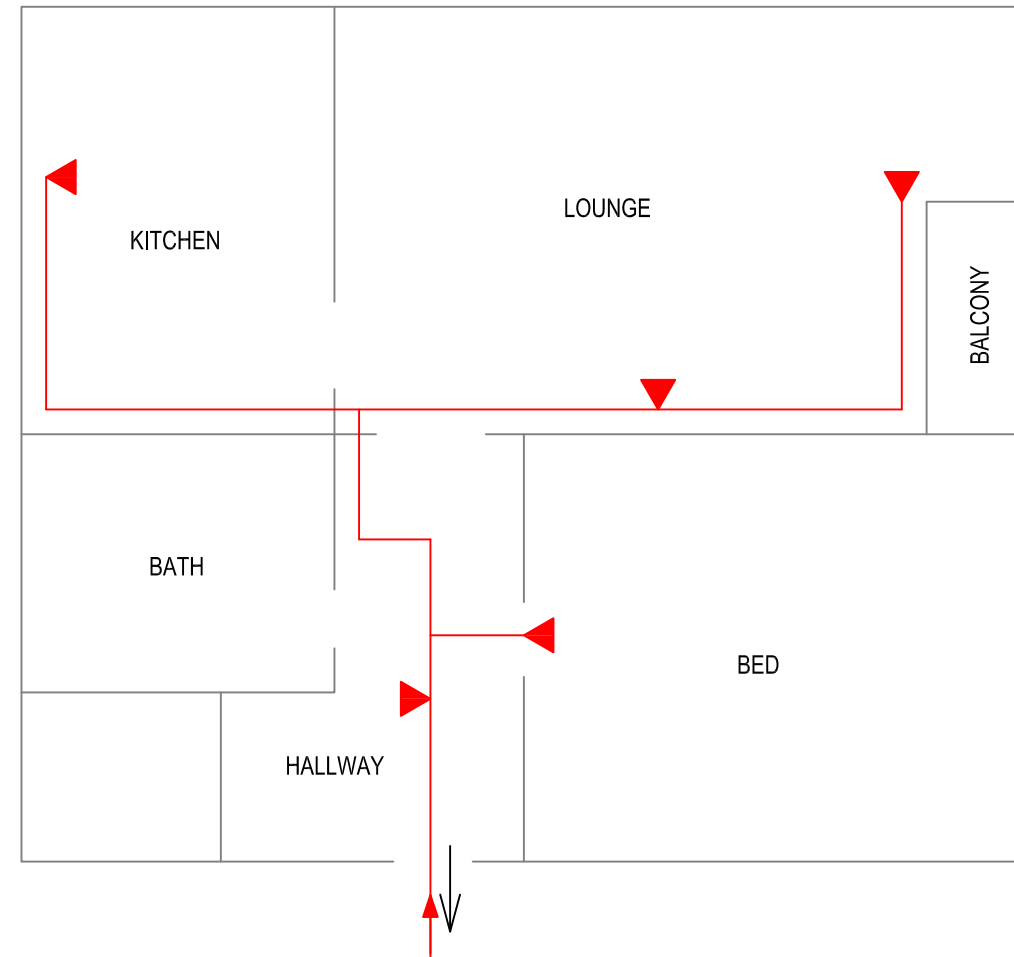

THIS SKETCH DOES NOT REPRESENT A
TRUE ACCURATE LAYOUT.
ITS FOR INFORMATION ONLY

MIDDLESEX ESTATE
PETTICOAT TOWER
TYPICAL FLAT LAYOUT/PROPOSAL
SCALE (N.T.S.)

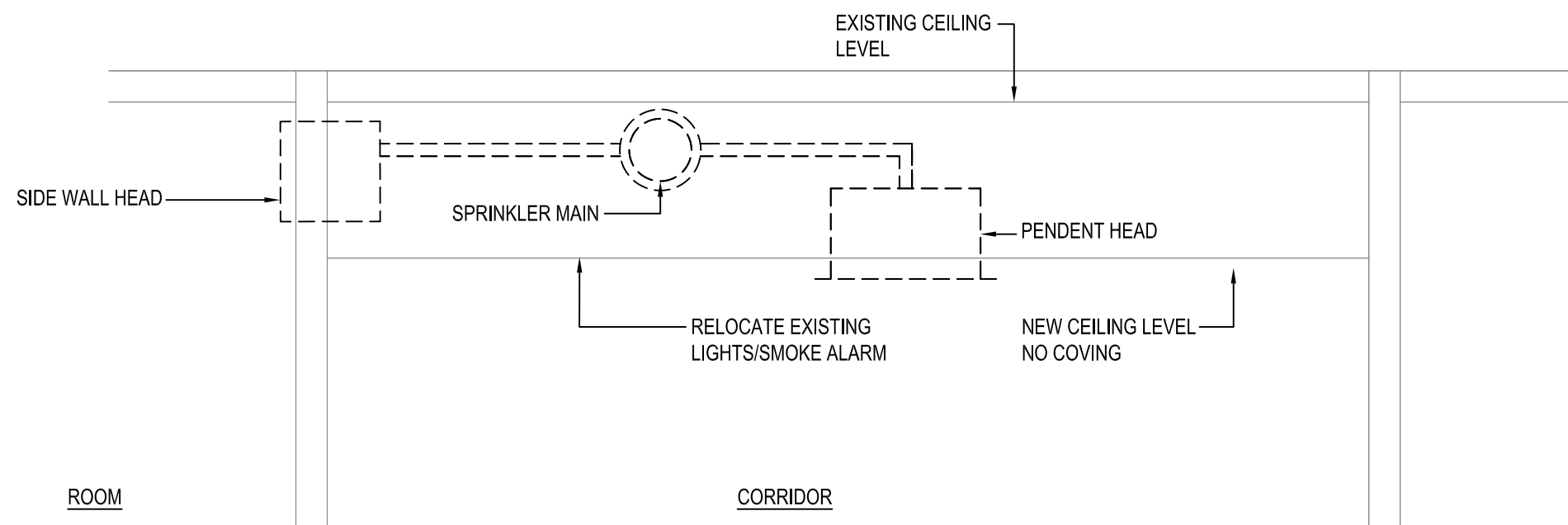

TYPICAL HIGH LEVEL SECTION
OF DWELLING CORRIDOR PROPOSAL

THIS SKETCH DOES NOT REPRESENT A
TRUE ACCURATE LAYOUT.
ITS FOR INFORMATION ONLY